

FACTS²™ C-SAM[®]

Fast Automated C-SAM[®] Tray Scanning System

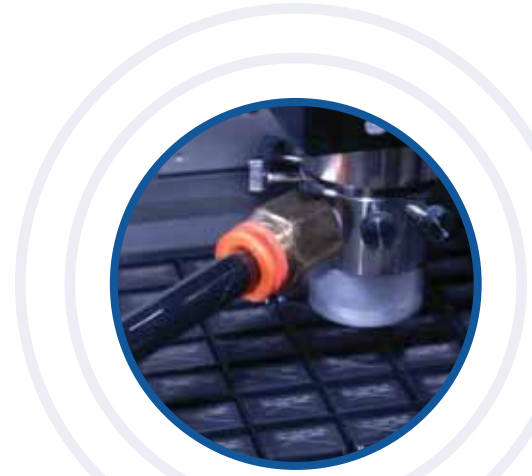

Non-immersion Imaging
utilizing Sonoscan's Waterfall™ transducer that minimizes the contact time between parts and a fluid couplant.

Ensure Defect-Free Production without Sacrificing Throughput

The FACTS² is a state-of-the-art quality control instrument that delivers high-resolution acoustic micro imaging at production speeds. The FACTS² fully automates the process, minimizing the need for operator interaction. The instrument can be provided with elevators or coupled with existing handlers for continuous, operator-free in-line scanning.



Features

- Sonoscan Waterfall™ transducer provides non-immersion scanning which minimizes risks of contamination, fluid ingestion and movement due to floating of parts
- In-Line or Stand-alone operation flexibility to best meet your production and quality control requirements
- Automated Data Analysis Package allows you to pre-define Accept/Reject criteria and automatically indicates rejected parts within the data image or file
- TurboSpeed™ provides faster imaging speeds at high frequencies with up to 2.5X increased image acquisition speed with high pixel densities
- Vacuum Hold Down option holds small parts in place and eliminates shifting during scanning to ensure the highest quality images
- Four-stage dryer with three air knives and vacuum unit to quickly and efficiently dry parts after scanning
- Temperature control options to maintain precise water temperature and ensure consistent imaging throughout the day, regardless of changes in ambient air temperature

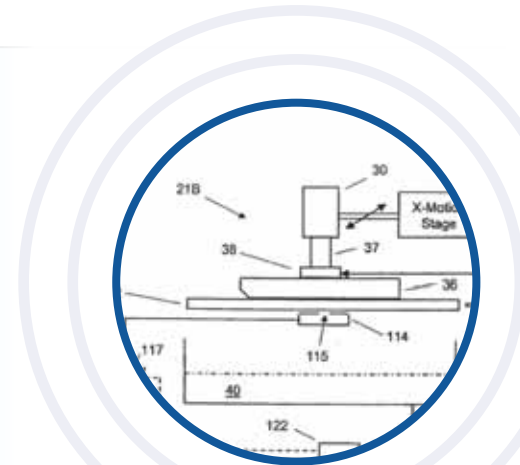

Vacuum Hold Down for Small Parts

uses a patented technology developed by Sonoscan that keeps small parts in place for imaging.



FACTS²™ C-SAM®

The FACTS²™ delivers state-of-the-art, automated AMI inspection for quality and process control. Delivering high throughput with minimal operator interaction, FACTS² helps ensure defect-free production with potentially no reduction in throughput.

FACTS² automatically inspects up to 10,000 integrated circuits per hour. Up to 35 JEDEC trays of singulated ICs can be stacked as a batch, or trays can be inspected as part of an in-line process. In addition, the FACTS² can also handle multi-layer ceramic chip capacitors, flip chips and other components.

Sensor-equipped elevators and rails guide each tray through the scan chamber. Sonoscan's proprietary Waterfall™ transducer quickly scans each tray without requiring immersion, and with no loss of resolution. The FACTS² even has the ability to scan multiple discrete levels within the packages (die face and die attach, for example) with no loss of speed.

Once inspected, the trays are dried and restacked or handed off to another process or handler. Any previously hidden internal packaging defects, including voids, disbonds, delaminations and cracks are clearly identified. Batch and lot data can be accessed either as images or tabulated analysis data from spreadsheets and tray maps. If desired, accept/reject criteria can be set to visually identify defective components within the data automatically. Small defects in potentially innocuous locations can also be sorted into various marginal categories based on your specific quality standards.



Leaders in Nondestructive Internal Inspection



Since its inception, Sonoscan has focused on developing superior Acoustic Micro Imaging (AMI) technology to help our customers build higher quality products. Sonoscan remains the most trusted authority on the application of AMI for nondestructive internal inspection and analysis, and holds more US and Foreign Patents related to AMI technology than any other manufacturer.

Sonoscan delivers:

- **Superior Image Quality** by being the only AMI company with our own transducer/lens development lab and fabrication facility
- **Extraordinary Data Accuracy** through our proprietary signal processing algorithms, analysis functions and color maps
- **High Throughput Rates** by developing the most advanced features and instruments
- **Unsurpassed Technical Expertise** with more than 20 dedicated and highly experienced AMI applications engineers on staff

For a complete list of FACTS²™ specifications, please contact Sonoscan at 847-437-6400.